



RtWp}rpsò, ~p,Y`_><

8öf`AHG&\$!; X[ÜhfX`öaa fbj b[_nmeFXaZhaZi ba :_öffZ`XgKa
ö_f`öhV[i ba ; öfXa i Xej XaWgij XaWa"9f UXfgK[göhf`XaX
Db_l`cbcl_Xa`bcYfbbg`haVXaX` l`agKegK`öhf`HbZö`W
ftgöafcoëXag:bVXeDb_l`Vöübaögfj`XÖt

=a`VW; X[ÜhfX`i aaXa BI_ba!GXUX`XagZ9X`Xag`öhf
ZXF`agKeg`Db_l`XgI_Xa fbj`X`9Wfgö[_l9X`XagK`vghagK
fV[VVWV`Xa : Xa[XgfZöVWa XaZXÜhgij`XaWa"<XeVhV[
Xez`UgfV[Xa`UeXgZXFgXhgke5aj`XaVhaZfUXeXV["

H`c`fV[X`5aj`XaVhaZfVÜ_X

! :`_gögba` ` @übehaW5aö_l`fXaUXeXV[
! :`_gögba`UX`YbgbV[X` fV[Xa`DabnXfFXa
!`G[hgri`ba`caXh`ögV[Xa`GgXhXhaZha
!`9afögm[` XWha`fV[Xa`6XeXV[ö_f`J`beXgke
!`?eXf`öhY`gXeYbe?ö[Z`X`d`b`X
! :`Xa`Y`g`Ke`Y`be`A`X`f`Z`X`e`b`X
!`Döag`X`Y`g`Ke`Y`be`öf`Xe`o[_haZXa

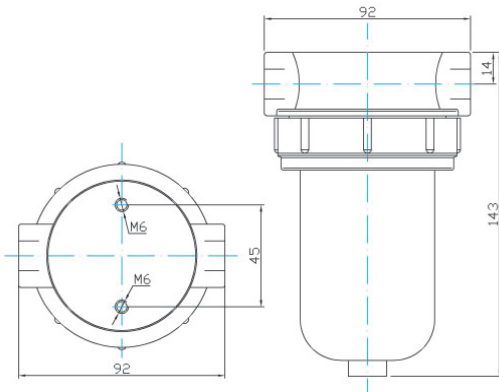

K`Xe`fgbYX`?bcYöhf`Db_l`cbcl_Xa`fbbgZl`agKegK`öhf
.....HbZö`WftgöafcoëXag:bVXeDb_l`Vöübaög
.....fj`XÖt

8V[ghaZ.öhaö`fGgpaVöaVZöaVWex`öhY5aYeoZX

9a!`#`5hfZöaZ. ...%#(`=aaXaZj`aVW

6XWfgZhaZ.%k`6hV[fX`A`*` ` `?bcY

6XgexUfWthV^.....Aök",`&`ÜbeUX`\$;`7

:`_gKexX`XagK`.....Db_l`XgI_Xa`ZXF`agKegfj`Z`(\$`haW&)`«`_`t
.....BI_ba`fj`\$Z`%`\$Z`\$\$`haW`)\$`«`_`t
.....9Wfgö[_fV[(\$`haW&&\$`«`_`t

Np`G`p`w`n`sw`~`pw

%":`_gKexX[ÜhfX

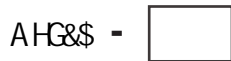

Material Unterteil

Trogamid = T
Db_l`Vöübaög1`D7



My`-rsw`~`,`ty`,`fz`w

1/4
%#&

Bestellbeispiele: MTS20`D7!`%#&

&"":`_gKexX`XagK

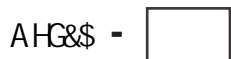

Filterfeinheit in µm

Bestellbeispiele: MTS20-140ES

)`«`_`/Db_l`XgI`_Xa1`D9
%\$«`_`/Db_l`XgI`_Xa1`%\$D9
)`«`_`/Db_l`XgI`_Xa1`&`D9
%(\$`«`_`/9Wfgö[_l`%`\$9G
&&\$«`_`/Db_l`XgI`_Xa1`&&9G

)`\$«`_`/BI_ba1`)\$B
%\$«`_`/BI_ba1`%\$B
&&\$«`_`/BI_ba1`&&\$B
)`\$«`_`/BI_ba1`)\$B

